

A One-Pot Three-Component Radiochemical Reaction for Rapid Assembly of ^{125}I -Labeled Molecular Probes

Ran Yan,^{†,‡} Kerstin Sander,[†] Eva Galante,[†] Vineeth Rajkumar,[‡] Adam Badar,[§] Mathew Robson,[‡] Ethaar El-Emir,[‡] Mark F. Lythgoe,[§] R. Barbara Pedley,[‡] and Erik Årstad^{*,†}

[†]Institute of Nuclear Medicine and Department of Chemistry, University College London, 235 Euston Road (T-5), London NW1 2BU, U.K.

[‡]UCL Cancer Institute, University College London, 72 Huntley Street, London WC1E 6BT, U.K.

[§]Centre for Advanced Biomedical Imaging, Division of Medicine, University College London, 72 Huntley Street, London WC1E 6BT, U.K.

S Supporting Information

ABSTRACT: Nuclear imaging in conjunction with radioactive tracers enables noninvasive measurements of biochemical events *in vivo*. However, access to tracers remains limited due to the lack of methods for rapid assembly of radiolabeled molecules with the prerequisite biological activity. Herein, we report a one-pot, three-component, copper(II)-mediated reaction of azides, alkynes, and [^{125}I]iodide to yield 5- [^{125}I]iodo-1,2,3-triazoles. Using a selection of azides and alkynes in a combinatorial approach, we have synthesized a library of structurally diverse ^{125}I -labeled triazoles functionalized with bioconjugation groups, fluorescent dyes, and biomolecules. Our preliminary biological evaluation suggests that 5- [^{125}I]iodo-1,2,3-triazoles are resistant to deiodination *in vivo*, both as small molecular probes and as antibody conjugates. The ability to incorporate radioactive iodide into triazoles directly from the parent azides and alkynes makes the method broadly applicable and offers the potential to rapidly assemble molecular probes from an array of structurally diverse, and readily available, building blocks.

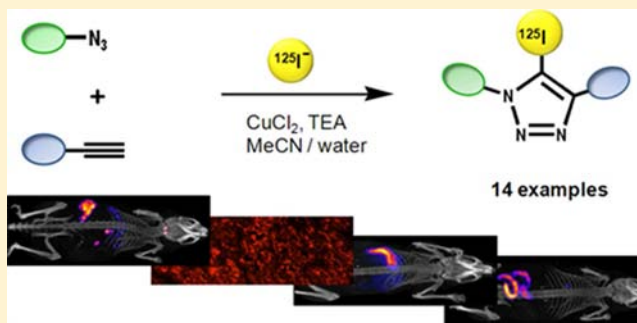

■ INTRODUCTION

Nuclear imaging in conjunction with radioactive tracers enables noninvasive measurements of biochemical events *in vivo*, and has become an invaluable tool for biological research and to diagnose disease. Yet tracer development remains exceedingly challenging as few methods are available that allow rapid assembly of radiolabeled molecules with the prerequisite biological activity. While the optimal choice of radionuclide depends on the intended application, as well as the structural requirements of the biological target, the numerous isotopes of iodine available support widespread use across biological research (^{125}I), diagnostic imaging ($^{123,124}\text{I}$), and radiotherapy (^{131}I).¹

Labeling with radioiodine is largely restricted to electrophilic reactions with activated aromatic groups, and iodo-demetalation of aryls and alkenes, using organotin or silicon precursors.^{1–3} Oxidative addition of radioiodine to electron-rich aromatic moieties offers a convenient method for labeling, but the resulting tracers are prone to rapid deiodination *in vivo*, limiting the practical applications to tyrosine-containing peptides and proteins.⁴ The use of organometallic precursors is often preferred as it enables labeling of nonactivated aromatic groups, as well as alkenes, and allows design of tracers with

increased metabolic stability.^{1–4} However, the need to independently prepare nonradioactive reference compounds and precursors for labeling makes structural alterations tedious and preparation of tracers with complex functional groups difficult.

We envisaged that the copper-catalyzed reaction of azides, alkynes, and electrophilic iodine to give 5-iodo-1,2,3-triazoles could give access to highly functionalized radiolabeled tracers in a single step (Scheme 1).⁵ In our initial report, we demonstrated the concept using a copper(II)-mediated one-pot reaction to synthesize a ^{125}I -labeled trifunctionalized reagent for multiscale imaging with optical and nuclear techniques.⁶ Here, we disclose a broadly applicable and highly efficient method that offers the potential to rapidly assemble an array of structurally diverse 5- [^{125}I]iodo-1,2,3-triazoles directly from the parent azides and alkynes. Imaging studies with single photon emission tomography (SPECT) suggest that the resulting 5- [^{125}I]iodo-1,2,3-triazoles are resistant to deiodination *in vivo*.

Received: August 9, 2012

Published: November 29, 2012

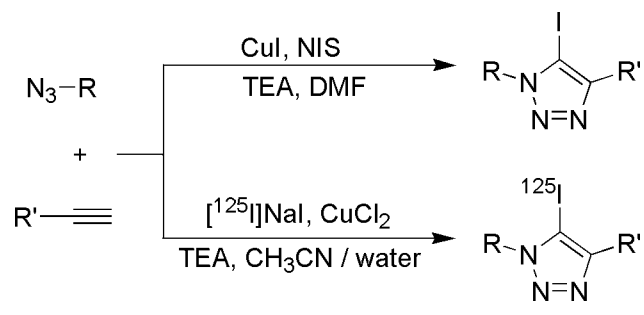
Scheme 1. Synthesis of 5- [¹²⁵I,¹²⁷I]Iodo-1,2,3-triazoles

RESULTS AND DISCUSSION

Synthesis. To evaluate the impact of the chemical environment on the labeling efficiency, we investigated the reactivity of azides and alkynes bearing aliphatic, benzylic, aromatic, and heterocyclic moieties. Azides **1a–f** and alkynes **2a–f** (Table 1) were synthesized as previously described or obtained from commercial sources.^{6–10} The azide **1g** was obtained in 40% overall yield from 1-benzhydryl-piperazine by alkylation with 2-bromoethanol, reaction of the corresponding alcohol with thionyl chloride, and substitution of the resulting chloride with azide. Reaction of biotin with thionyl chloride and subsequent treatment of the acyl chloride with *N*-methyl-propargylamine provided alkyne **2g** in 65% yield. Treatment of 6-chloropurine with sodium hydride, followed by alkylation with propargyl bromide gave alkyne **2h** in 58% yield. A modified literature method was adopted for the preparation of the nonradioactive 5-iodo-1,2,3-triazoles **3a–n**.⁵ Treatment of the respective azides **1a–g** and alkynes **2a–h** with copper(I) iodide, triethylamine (TEA), and *N*-iodosuccinimide (NIS) provided the target compounds **3a–n** (Scheme 1), albeit in moderate to poor yields. While we aimed to rapidly access the nonradioactive reference compounds for structural characterization, it should be noted that other synthetic methods have been reported to afford 5-iodo-1,2,3-triazoles in good to excellent yields.^{5,11,12}

Radiochemistry. Initially, we used the azide **1d** and alkyne **2f** (Table 1, entry 10) to screen a number of copper salts, chelators, oxidizing agents, and solvents, with the aim of identifying a catalytic system that would allow formation of [¹²⁵I]iodotriazole **3j** directly from aqueous non-carrier-added (n.c.a.) [¹²⁵I]NaI. While several oxidants were effective in combination with copper(I) salts, including iron(III) chloride, the use of copper(II) chloride in combination with TEA provided a convenient source of both oxidant and catalyst for the reaction. Under the optimized conditions, the triazole [¹²⁵I] **3j** was formed in 80 ± 3% analytical radiochemical yield (RCY) by reacting azide **1d**, alkyne **2f** (1.0 equiv), copper(II) chloride (1.0 equiv), and TEA (1.5 equiv) with sodium [¹²⁵I]iodide in a solution of water and acetonitrile (1:10) for 90 min at room temperature. Formation of the corresponding non-iodinated triazole was sluggish, and the azide **1d** and alkyne **2f** remained largely intact in the reaction mixture.











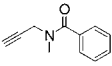
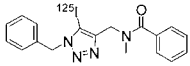

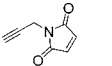
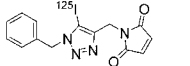

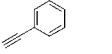
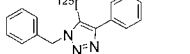

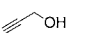
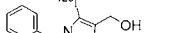
To explore the scope of the method, we subjected the alkynes **2a–e** to the labeling conditions described above, using benzyl azide (**1a**) as the “click partner”. Unexpectedly, the RCY for the triazole [¹²⁵I]**3a** (20 ± 2%, entry 1) was substantially lower than that for [¹²⁵I]**3j**, despite the near identical chemical environment in the immediate surroundings of reactive groups of the azides **1a** and **1d**, and the alkynes **2a** and **2f**. *N*-Propargyl maleimide (**2b**) proved more reactive and led to the formation

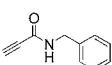
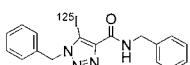
of triazole [¹²⁵I]**3b** in 57 ± 4% RCY (entry 2). Phenylacetylene (**2c**) and propargyl alcohol (**2d**) gave poor RCYs of the corresponding triazoles [¹²⁵I]**3c** and [¹²⁵I]**3d** (9 ± 1% and 27 ± 19%, respectively, entries 3 and 4), whereas the propargyl amide **2e** afforded triazole [¹²⁵I]**3e** in 60 ± 8% RCY (entry 5). To investigate the impact of the chemical environment on the reactivity of azides, we treated the propargyl amide **2e** with phenyl azide (**1b**), and the aliphatic ester **1c**, which provided the resulting triazoles [¹²⁵I]**3f** and [¹²⁵I]**3g** in disappointing RCYs of 3 ± 1% and 17 ± 2%, respectively (entries 6 and 7). Whereas the alkynes **2b** and **2e** gave comparable yields when reacted with benzyl azide (**1a**), the use of *N*-propargyl maleimide (**2b**) in combination with the aliphatic azide **1c** led to a marked increase in RCY (30 ± 2%, entry 8) as compared with that using **2e**.

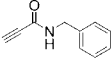
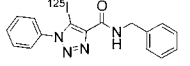
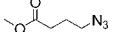
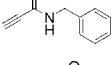
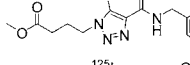
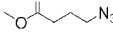
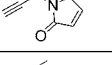
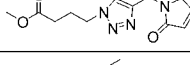
Our initial results were perplexing, as none of the model compounds investigated gave comparable RCYs to those of the azide **1d** and alkyne **2f**, which were employed for the explorative studies. However, we noted that for several low-yielding reactions a precipitate gradually formed, suggesting that the solubility of the reactants strongly influences the outcome of the reaction. Heating of the reaction mixtures to 60 °C was sufficient to retain homogeneous solutions and gratifyingly led to dramatic increases in RCYs. With the exception of triazoles [¹²⁵I]**3f** and [¹²⁵I]**3g**, which were obtained in a moderate 39 ± 1% and 54 ± 16% RCYs (entries 6 and 7), reactions of the azides **1a** and **1c** with the alkynes **2a–e** for 90 min at 60 °C provided the corresponding triazoles [¹²⁵I]**3a–e** and [¹²⁵I]**3h** in excellent to near quantitative RCYs (entries 1–5 and 8). While it is conceivable that the increased reactivity observed with heating is mediated by several factors, including kinetic energy and concentration of the reaction mixture within the reaction vial, the moderate effect of heating on the RCYs for triazoles [¹²⁵I]**3j** and [¹²⁵I]**3m** (entries 10 and 13) is supportive of the notion that solubility is a deciding factor for labeling efficiency.

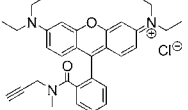
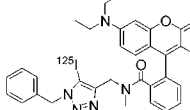
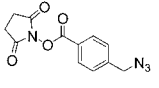
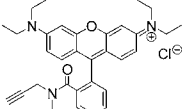
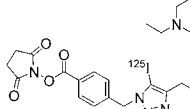
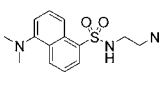
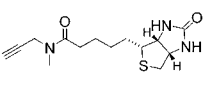
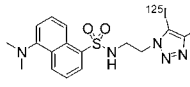
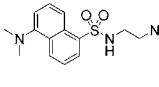
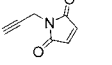
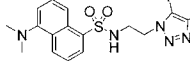
Encouraged by the results, we set out to prepare [¹²⁵I]-iodotriazoles, functionalized with selected bioconjugation groups, fluorescent dyes, and biomolecules, as putative molecular probes for imaging with SPECT. The target compounds [¹²⁵I]**3i–m** were all obtained in excellent RCYs (entries 9–13), demonstrating the versatility and robustness of the reaction. The rhodamine derivative [¹²⁵I]**3i** was prepared as a candidate tracer for imaging of mitochondrial membrane potentials,¹³ whereas the biotin-derived triazole [¹²⁵I]**3k** was designed for pretargeting strategies in conjunction with avidin, or streptavidin, and may find use for imaging (^{123,124,125}I) as well as radioimmunotherapy (¹³¹I).^{14,15} The dual optical and nuclear labeling reagents [¹²⁵I]**3j** and [¹²⁵I]**3l** were prepared to give rapid access to protein-derived tracers for multiscale imaging through lysine or thiol conjugation, respectively. The 6-chloropurine [¹²⁵I]**3m** may enable imaging of drug efflux transporter function^{16,17} and exemplifies the potential to prepare tracers suitable for labeling with ¹⁸F, as well as radioiodine. Finally, to investigate if a copper-chelating group, i.e. piperazine, is tolerated in the radiochemical reaction we prepared [¹²⁵I]**3n**, a derivative of the first-generation antihistamine hydroxyzine. Despite attempts to optimize the labeling conditions, low RCYs were observed (15 ± 19%, entry 14), and the reproducibility was poor, pointing to a limitation with this method. In preparative runs using 25–95 MBq of [¹²⁵I]NaI, the triazoles [¹²⁵I]**3i–l** were obtained in 70–80% RCY after

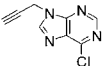
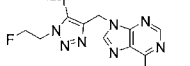
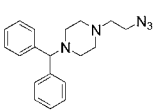
Table 1. Radiochemical Yields for 5-¹²⁵I]Iodo-1,2,3-triazoles^d

Entry	Azide	Alkyne	Product	RCY ^a
1	1a 	2a 	3a 	92 ± 6 (20 ± 2)
2	1a 	2b 	3b 	87 ± 4 (57 ± 4)
3	1a 	2c 	3c 	99 ± 2 (9 ± 1)
4	1a 	2d 	3d 	90 ± 5 (27 ± 19)
5	1a 	2e 	3e 	96 ± 8 (60 ± 8)
6	1b 	2e 	3f 	39 ± 1 (3 ± 1)
7	1c 	2e 	3g 	54 ± 16 (17 ± 2)
8	1c 	2b 	3h 	90 ± 1 (30 ± 2)
9	1a 	2f 	3i 	92 ± 4 (75 ± 4)
10	1d 	2f 	3j 	89 ± 2 (80 ± 3) ^b
11	1e 	2g 	3k 	97 ± 0 (35 ± 1)
12	1e 	2b 	3l 	90 ± 4 (26 ± 3)
13	1f 	2h 	3m 	87 ± 1 (80 ± 2)
14	1g 	2d 	3n 	15 ± 19 ^c (0)

^aAnalytical radiochemical yields ± standard deviation. ^b*n* = 8. ^c0.5 equiv of TEA was used, *n* = 6. ^dAll reactions were carried out using 2–5 MBq [¹²⁵I]NaI and 1.0 μmol of the azides and alkynes in the presence of copper(II) chloride (1.0 equiv) and TEA (1.5 equiv) at room temperature (yields in brackets) or with heating to 60 °C for 90 min. All experiments were carried out in triplicates unless otherwise specified.

HPLC purification, with a specific activity in the range of 2–3 GBq/μmol.

As radioactive iodide is supplied in aqueous solutions, the amount of radioactivity that can be used, if a concentration step is to be avoided, is governed by the total volume of water that can be added to the reaction mixture. Using the formation of [¹²⁵I]3j as an example, we investigated how the water content, the concentration of the reagents, and the temperature affect the labeling efficiency (Table 2). During our explorative work, we carried out the reactions on a 1.0 μmol scale in a total volume of 66 μL of water and acetonitrile (1:10), using 2–5

MBq [¹²⁵I]NaI. When the water content was increased from 6 to 12 μL, the RCY of [¹²⁵I]3j decreased sharply from 80 ± 3% to 31% (entry 2). Doubling the volume of the solvent, while keeping the ratio of water and acetonitrile to 1:10, had a similarly detrimental effect (entries 3 and 4). The most practical solution for preparing higher activity levels of [¹²⁵I]3j was therefore to increase the amounts of reagents used from 1.0 μmol to 2.0 μmol, which enabled us to use up to 12 μL/180 MBq of aqueous [¹²⁵I]NaI. Starting with 100 MBq of [¹²⁵I]NaI, [¹²⁵I]3j was obtained in 74 ± 4% isolated RCY with a specific activity of 9 GBq/μmol (entry 5). At this scale, 5-¹²⁵I]iodo-

Table 2. Influence of Water Content and Concentration on RCYs for Formation of Labeling Reagent [¹²⁵I]3j

entry	MeCN:water (μL)	temp. (°C)	RCY ^c (%)
1 ^a	60:6	RT	80 ± 3 (n = 8) 72 ± 4 (n = 5) ^d
2 ^a	60:12	RT	31
3 ^a	120:12	RT	37
4 ^a	120:12	60	53 ± 13 (n = 3)
5 ^b	120:12	RT	87 ± 3 (n = 6) 74 ± 4 (n = 6) ^d

^aA solution of rhodamine **2f** (1.0 μmol), CuCl₂ (1.0 μmol) and TEA (1.5 μmol) was added to [¹²⁵I]NaI in water before addition of azide **1d** (1.0 μmol) and left to react for 90 min. ^bThe reaction was scaled up to 2.0 μmol. ^cRCY is the mean value of *n* experiments ± standard deviation. When not specified, *n* = 1. ^dIsolated RCY.

1,2,3-triazoles can readily be prepared in sufficient activity levels for preclinical imaging studies; however, scale-up for clinical applications may require aqueous solutions of radioiodine to be concentrated before use.

Mechanistic Studies. When optimizing the labeling of [¹²⁵I]3j we found that the addition sequence of the reagents was important, with the highest yields obtained when the alkyne **2f**, copper(II) chloride, and TEA were combined prior to addition of [¹²⁵I]NaI and the azide **1d**. Interestingly, in the absence of the azide **1d** a new radiolabeled compound was formed in 10–60% RCY that previously had only been observed as a minor side product (<2% RCY). To investigate the nature of the side product we used the alkyne **2c** as a model compound. When **2c** was treated with copper(II) chloride, TEA, and [¹²⁵I]NaI at ambient temperature, no radiochemical reaction took place. However, heating the reaction mixture to 60 °C for 90 min led to formation of 1-([¹²⁵I]iodoethynyl)-benzene ([¹²⁵I]4) (Scheme 2) in 84 ± 3% (n = 3) RCY. The

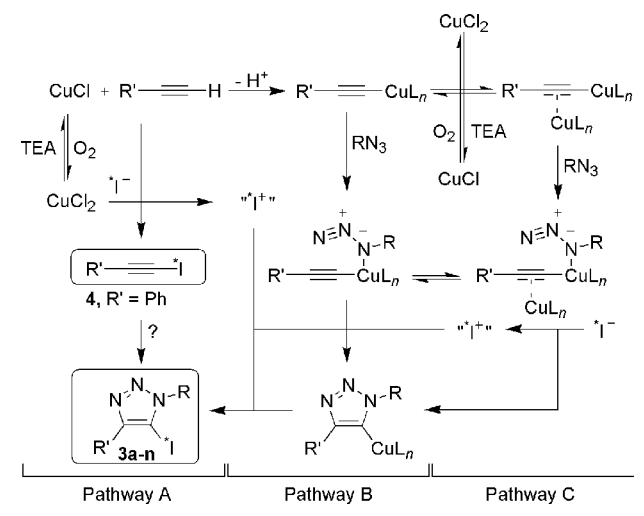
Scheme 2. Potential Mechanistic Pathways for Copper(II)-Mediated Formation of 5- [¹²⁵I]Iodo-1,2,3-triazoles

identity of the radioactive product was confirmed by coelution with the nonradioactive reference compound. The results bear a striking resemblance to the RCYs obtained when alkyne **2c** was reacted with azide **1a** (9 ± 1% and 99 ± 2% at room temperature and with heating to 60 °C, respectively, Table 1, entry 3), suggesting that 1-iodoalkynes may be intermediates in

the copper-catalyzed cycloaddition reaction (Scheme 2, pathway A).

In order to explore this possibility further, we attempted to react the azide **1a** with 1-([¹²⁵I]iodoethynyl)benzene ([¹²⁵I]4) in the presence of copper powder as well as several copper(I) and copper(II) salts; however, the iodoalkyne [¹²⁵I]4 rapidly decomposed under these conditions (30 min at 60 °C). When [¹²⁵I]4 was prepared *in situ* with copper(II) chloride and TEA prior to addition of azide **1a**, the iodoalkyne [¹²⁵I]4 remained intact. Interestingly, all the aforementioned sources of copper mediated rapid scrambling of iodine when added to a mixture of [¹²⁵I]NaI and the nonradioactive iodoalkyne **4**. In the presence of the azide **1a**, copper(I) iodide yielded both the iodotriazole [¹²⁵I]3c (12% RCY) and [¹²⁵I]4 (8% RCY). Comparable results were obtained with copper powder and copper(I) oxide in the absence of TEA, with formation of iodoalkyne [¹²⁵I]4 (50% and 62% RCY) as well as the iodotriazole [¹²⁵I]3c (10% and 19% RCY). In contrast, copper(I) and copper(II) chloride gave [¹²⁵I]4 as the sole radiochemical product in 46% and 76% RCY, respectively. While we cannot exclude the possibility that iodoalkynes are intermediates in the reaction, the failure of copper(I) and copper(II) chloride to catalyze the cycloaddition of [¹²⁵I]4 and azide **1a** makes this unlikely.

Under inert atmosphere, complexes of copper(II) chloride and TEA can undergo reduction to copper(I), yet in the presence of air they rapidly revert back to their 2+ oxidation state.^{18,19} To investigate the oxidation state of the catalytic system, hydrogen peroxide (1.0 equiv) was added to the copper(II) chloride/TEA complex prior to addition of the alkyne **2c**. Subsequent reaction with the azide **1a** and [¹²⁵I]NaI for 30 min at 60 °C led to formation of 1-([¹²⁵I]iodoethynyl)-benzene ([¹²⁵I]4) in quantitative RCY. The absence of the triazole [¹²⁵I]3c from the reaction mixture implies that copper(I) is required for the cycloaddition reaction to occur. Yet, addition of the alkyne **2c** to a solution of copper(I) chloride and TEA in acetonitrile results in immediate precipitation of the corresponding copper(I) acetylide as a yellow solid. As a homogeneous burgundy solution is obtained when copper(II) chloride is used, the corresponding TEA complex is likely to be predominantly in the 2+ oxidation state, while still providing a source of copper(I).

The mechanism for formation of 5-iodo-1,2,3-triazoles from azides and alkynes remains elusive, and none of the pathways suggested to date can fully explain the reported experimental data.²⁰ In their pioneering work, Wu et al. proposed formation of an intermediate copper(I) triazolyl complex, which upon reaction with electrophiles gives rise to 1,4,5-trisubstituted-1,2,3-triazoles.⁵ More recently, Buckley et al. demonstrated that dinuclear copper(I) ladderane complexes can catalyze the reaction of azides and iodoalkynes in the presence of TEA to give 5-iodotriazoles.²¹ To account for this observation it was proposed that nucleophilic amines mediate transfer of iodine from iodoalkynes to a dinuclear copper(I) triazolyl intermediate, and that the liberated terminal alkyne serves to regenerate the catalytic complex.

Under the conditions described here, it is plausible that [¹²⁵I]NaI is oxidized in the presence of copper(II) chloride and TEA, and that electrophilic ¹²⁵I subsequently undergoes metal-halide exchange with a copper(I) triazolyl complex (Scheme 2, pathway B).²² Indeed, oxidation of [¹²⁵I]NaI with hydrogen peroxide (0.36 equiv) followed by addition of copper(I) chloride, TEA, azide **1a**, and the alkyne **2c** provided the triazole

[¹²⁵I]3c. While the RCY was lower than that obtained with copper(II) chloride and [¹²⁵I]NaI (24% vs 45%), precipitation of the copper(I) acetylide is likely to have impaired the reaction rate. However, this pathway does not explain why formation of 5-[¹²⁵I]iodotriazoles is favored over the corresponding 5-prototriazoles despite the low concentration of n.c.a. [¹²⁵I]NaI.

While we observed efficient transfer of [¹²⁵I]iodide to (1-iodoethyl)benzene 4 in the presence of copper(II) chloride and TEA, no further reaction took place in the presence of azide 1a. This finding contradicts the pathway proposed by Buckley et al.,²¹ since reaction of TEA with the iodoalkyne 4 to give a triethyliodoammonium ion would also provide a source of the alkyne 2c and hence should result in formation of the iodotriazole [¹²⁵I]3c. Instead, under the conditions reported here, iodide may act as a bridging ligand to promote formation of a dinuclear copper(I) ladderane complex with enhanced reactivity (Scheme 2, pathway C).²³ Subsequent reaction with an azide would result in formation of a dinuclear copper(I)–triazolyl complex with iodide ideally positioned to undergo sequential oxidation and electrophilic substitution, providing the resulting 5-iodotriazole. This pathway can explain the high selectivity for formation of iodotriazoles, and also provides a rationale for why triiodide ions are more reactive than iodine in this reaction.²⁴

Preliminary Biological Evaluation. To explore the potential applications of 5-[¹²⁵I]iodo-1,2,3-triazoles for *in vivo* imaging, we conjugated the dual optical and nuclear labeling reagent [¹²⁵I]3j to ASB7, a mouse monoclonal antibody (mAb) specific to carcinoembryonic antigen (CEA). CEA is expressed by most gastrointestinal tumors, and ASB7 has been extensively used for radioimmunotherapy of colorectal cancer in preclinical and clinical studies.^{25–27} Incubation of n.c.a. [¹²⁵I]3j with ASB7 for 1 h provided the [¹²⁵I]3j/ASB7 conjugate in 26% RCY after purification with a size exclusion cartridge (80% protein recovery). Addition of excess nonradioactive 3j (20 equiv) to the reaction mixture had a limited effect on the conjugation efficiency, and provided ASB7 with an average of six to eight fluorescent groups per antibody (22% RCY).⁶

As previously reported, in mice bearing human colorectal xenografts (SW1222), the biodistribution of [¹²⁵I]3j/ASB7 was similar to that of the antibody when it was labeled with ¹²⁵I alone using the Chloramine-T method. However, conjugation of [¹²⁵I]3j to ASB7 reduced the tumor uptake and also led to increased liver uptake and more rapid blood clearance.⁶ In preliminary studies, we did not see any correlation between the distribution of [¹²⁵I]3j/ASB7 and the number of fluorescence groups (1–6) per antibody, suggesting that the biological properties of ASB7 are affected by the conditions used for lysine conjugation rather than by the physicochemical properties of the labeling reagent [¹²⁵I]3j. In this respect, it is worth noting that the liver uptake of [¹²⁵I]3j/ASB7 (6.99 ± 0.16% ID/g 48 h postinjection) after conjugation with 6–8 fluorescent groups per antibody still compares favorably to that of other antibodies, such as [⁶⁴Cu]rituximab, that have been modified by lysine conjugation.²⁸

SPECT imaging of [¹²⁵I]3j/ASB7 demonstrated high retention in the tumor over the course of the experiment, with gradual clearance in off-target tissues, resulting in excellent contrast 5 days postinjection (Figure 1A). In separate experiments, nonradioactive 3j/ASB7 bearing 6–8 fluorescent groups per antibody was used to image CEA expression on a SW1222 xenograft section (Figure 1B). In our hands, the contrast and fluorescence intensity observed was comparable to

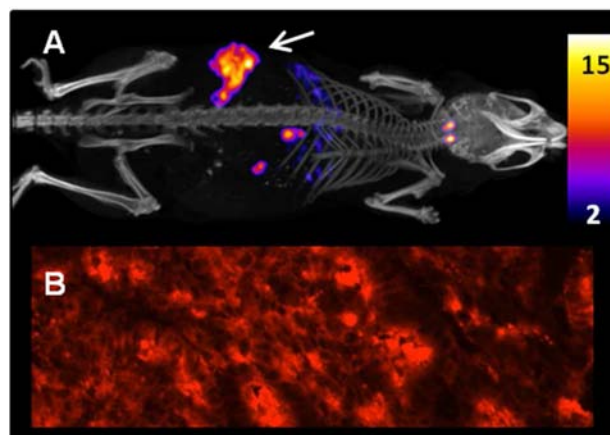

Figure 1. SPECT/CT image (A) of subcutaneous SW1222 tumor (1 cm³, indicated by arrow) 5 days after administration of 6.8 MBq [¹²⁵I] 3j/ASB7. The color bar represents counts per second. (B) Confocal image of a SW1222 xenograft section (100 μm × 350 μm) stained with 3j/ASB7.

that achieved when labeling ASB7 with a commercially available dye (Alexa Fluor 546), suggesting that 3j may find use as a low-cost alternative for fluorescent labeling of antibodies.

The propensity of iodinated compounds to undergo deiodination *in vivo* is limiting the use of radioiodine for biomedical applications. To assess the metabolic stability of 5-[¹²⁵I]iodo-1,2,3-triazole-derived small-molecule tracers we compared the distribution of rhodamine [¹²⁵I]3i and biotin [¹²⁵I]3k to that of [¹²⁵I]FIAU and [¹²⁵I]iodide using SPECT/CT (Figure 2). Images were acquired at 30 min and 2 h postinjection, using identical threshold levels to allow comparison of activity distribution across one order of magnitude. The uptake of radioactivity in the thyroid was used as a measure of deiodination *in vivo*. The rhodamine-derived tracer [¹²⁵I]3i showed high initial uptake in the spleen, with widespread distribution of activity in the abdomen at the later time point (Figure 2, A and B). The biotin derivative [¹²⁵I]3k was rapidly excreted to the intestines and showed negligible uptake in other tissues (Figure 2, C and D). In contrast, administration of [¹²⁵I]FIAU, a nucleoside-derived tracer for imaging of herpes simplex virus type 1 thymidine kinase (HSV1-*tk*),^{29,30} led to rapid accumulation of activity in the thyroid, stomach and bladder (Figure 2, E and F). Administration of [¹²⁵I]iodide gave a distribution pattern almost indistinguishable from [¹²⁵I]FIAU (Figure 2, G and H).

At 30 min p.i., the thyroid uptake after administration of [¹²⁵I]iodide was 7.49% of the whole body activity. In comparison, the corresponding values for the rhodamine [¹²⁵I]3i, the biotin [¹²⁵I]3k, and [¹²⁵I]FIAU were 0.92%, 0.51% and 4.22%, respectively. It should be noted that the metabolic fate of radiolabeled tracers depends on a number of factors, including physicochemical and biological properties, and that the rate of deiodination varies considerably even for compounds bearing iodine on comparable chemical moieties. In addition, scatter and attenuation limit the quantitative information that can be derived from SPECT. Nonetheless, the low uptake of activity in the thyroid, stomach, and bladder following administration of [¹²⁵I]3i and [¹²⁵I]3k suggests that 5-[¹²⁵I]iodo-1,2,3-triazoles are resistant to deiodination *in vivo*.

Recently, Valliant and co-workers reported the synthesis and *in vivo* distribution of a disubstituted [¹²³I]iodotriazole (I-TAAG) and its glutamate-urea-lysine conjugate.³¹ Adminis-

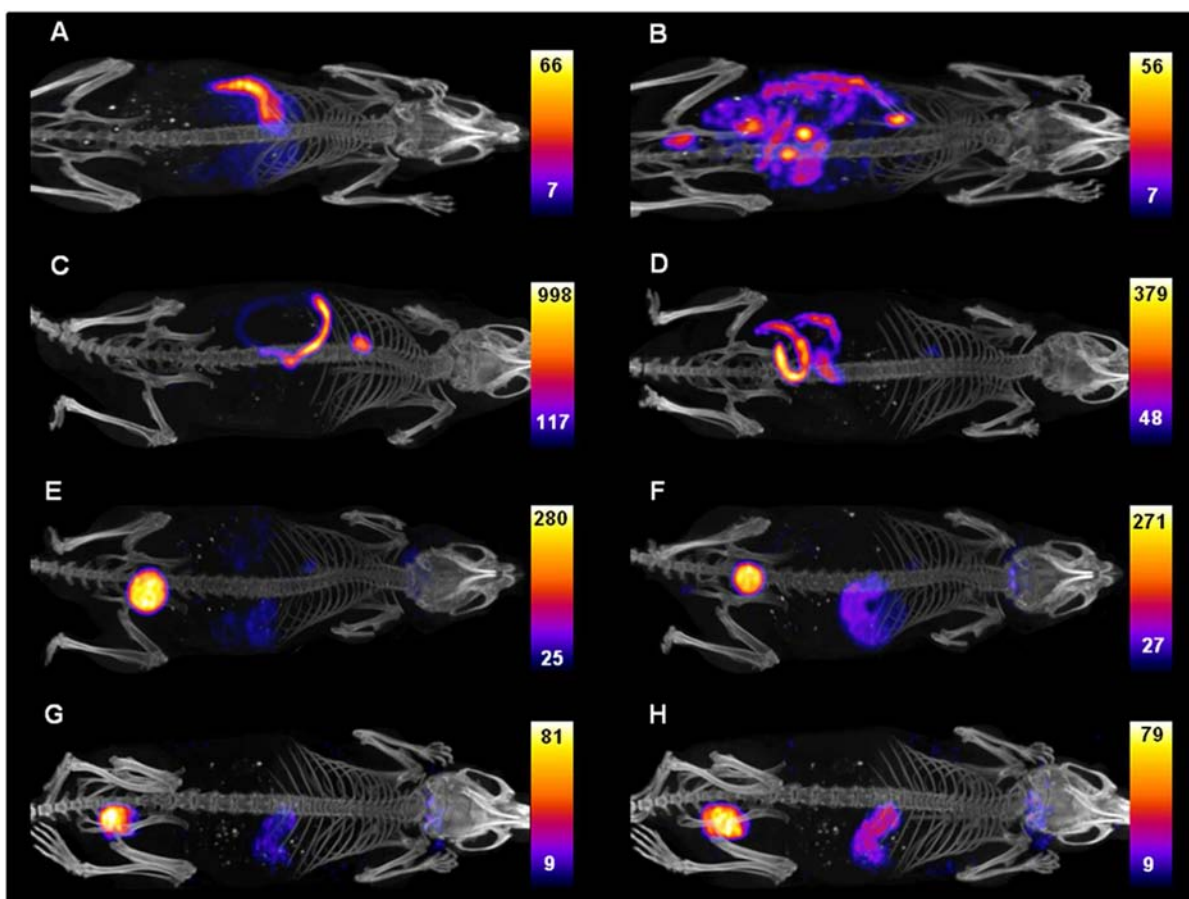

Figure 2. SPECT/CT images of BALB/c mice. Color bars represent counts per second with maximum and minimum threshold levels indicated. (A) Rhodamine $[^{125}\text{I}]3\text{i}$ at 30 min and (B) 2 h p.i. showing initial uptake in the spleen with widespread distribution in the abdomen at the later time point. (C) Biotin $[^{125}\text{I}]3\text{k}$ at 30 min and (D) 2 h postinjection (p.i.) showing rapid and almost exclusive excretion to the intestines. (E) $[^{125}\text{I}]$ FIAU at 30 min and (F) 2 h p.i. demonstrating rapid deiodination with uptake in the stomach and thyroid, and excretion to the bladder. (G) For comparison, the distribution of sodium $[^{125}\text{I}]$ iodide is shown at 30 min and (H) 1 h p.i.

tration of I-TAAG in mice led to significant accumulation of radioactivity in the thyroid within 1 h, indicative of rapid deiodination *in vivo*. While further studies are required to elucidate the biological properties of iodotriazoles, the increased steric hindrance of trisubstituted triazoles may account for the discrepancy in metabolic stability between I-TAGG, and the tracers reported herein.

CONCLUSIONS

We have developed a one-pot, copper(II)-mediated reaction that provides 5- $[^{125}\text{I}]$ iodo-1,2,3-triazoles directly from aqueous $[^{125}\text{I}]$ iodide and the parent alkynes and azides. The method is technically straightforward, robust, versatile, and high yielding, and provides rapid access to highly functionalized tracers. Using a combinatorial approach, we have prepared an array of $[^{125}\text{I}]$ iodotriazoles decorated with bioconjugation groups, fluorescent dyes, and biomolecules. Our preliminary biological evaluation indicates that 5- $[^{125}\text{I}]$ iodo-1,2,3-triazoles are resistant to deiodination *in vivo*, both as small molecular probes and as antibody conjugates. The added flexibility of trisubstituted triazoles, and their apparent resistance to metabolic deiodination, has the potential to transform the development of tracers for biomedical imaging and therapeutic applications.³²

ASSOCIATED CONTENT

Supporting Information

Experimental data for the synthetic and radiochemical procedures, spectroscopic data, radio-HPLC characterization, and imaging protocols are provided. This material is available free of charge via the Internet at <http://pubs.acs.org>.

AUTHOR INFORMATION

Corresponding Author

e.arstad@ucl.ac.uk

Present Address

¹King's College London, Division of Imaging Sciences and Biomedical Engineering Rayne Institute, St. Thomas' Hospital, London SE1 7EH, U.K. E-mail: ran.yan@kcl.ac.uk

Notes

The authors declare no competing financial interest.

ACKNOWLEDGMENTS

This work was undertaken at UCLH/UCL which is funded in part by the Department of Health's NIHR Biomedical Research Centres funding scheme (E.Å., R.Y.). The research leading to these results has received funding from the European Community's Seventh Framework Programme (FP7/2007-2013) under Grant Agreement Number 201380 ("Euripides") (K.S., E.G.). We acknowledge support from Cancer Research

UK (R.B.P., M.R.), European Union Seventh Framework Programme Grant 201342, and ADAMANT (E.E.E.), and by King's College London, UCL Comprehensive Cancer Imaging Centre CR-UK, and EPSRC, in association with the MRC and DoH (England) (V.R.).

REFERENCES

- (1) Adam, M. J.; Wilbur, D. S. *Chem. Soc. Rev.* **2005**, *34*, 153–163.
- (2) SeEVERS, R. H.; Counsell, R. E. *Chem. Rev.* **1982**, *82*, 575–590.
- (3) Årstad, E.; Hoff, P.; Skattebøl, L.; Skretting, A.; Breistol, K. J. *Med. Chem.* **2003**, *46*, 3021–3032.
- (4) Vaidyanathan, G.; Zalutsky, M. R. *Nat. Protoc.* **2007**, *2* (2), 282–286.
- (5) Wu, Y. M.; Deng, J.; Li, Y.; Chen, Q. Y. *Synthesis* **2005**, *18*, 1314–1318.
- (6) Yan, R.; El-Emir, E.; Rajkumar, V.; Robson, M.; Jathoul, A. P.; Pedley, R. B.; Årstad, E. *Angew. Chem., Int. Ed.* **2011**, *50*, 6793–6795.
- (7) Kele, P.; Li, X.; Link, M.; Nagy, K.; Herner, A.; Krisztián, L.; Béni, S.; Wolfbeis, O. S. *Org. Biomol. Chem.* **2009**, *7*, 3486–3490.
- (8) Stephen, A.; Hashmi, K.; Molinari, L.; Rominger, F.; Oeser, T. *Eur. J. Org. Chem.* **2011**, *12*, 2256–2264.
- (9) Link, M.; Li, X.; Kleim, J.; Wolfbeis, O. S. *Eur. J. Org. Chem.* **2010**, *36*, 6922–6927.
- (10) Glaser, M.; Årstad, E. *Bioconjugate Chem.* **2007**, *18* (3), 989–993.
- (11) Li, L.; Zhang, G.; Zhu, A.; Zhang, L. *J. Org. Chem.* **2008**, *73*, 3630–3633.
- (12) Hein, J. E.; Tripp, J. C.; Krasnova, L. B.; Sharpless, K. B.; Fokin, V. V. *Angew. Chem., Int. Ed.* **2009**, *48*, 8018–8021.
- (13) Zhou, Y.; Kim, Y. S.; Yan, X.; Jacobson, O.; Chen, X.; Liu, S. *Mol. Pharm.* **2011**, *8*, 1198–1208.
- (14) Lesch, H. P.; Kaikkonen, M. U.; Pikkarainen, J. T.; Yla-Herttuala, S. *Expert Opin. Drug Delivery* **2010**, *7* (5), 551–564.
- (15) Mohsin, H.; Jia, F.; Bryan, J. N.; Sivaguru, G.; Cutler, C. S.; Ketring, A. R.; Miller, W. H.; Simón, J.; Frank, R. K.; Theodore, L. J.; Axworthy, D. B.; Jurisson, S. S.; Lewis, M. R. *Bioconjugate Chem.* **2011**, *22*, 2444–2452.
- (16) Okamura, T.; Kikuchi, T.; Okada, M.; Toramatsu, C.; Fukushi, K.; Takei, M.; Irie, T. *J. Cereb. Blood Flow Metab.* **2009**, *29*, 504–511.
- (17) Okamura, T.; Kikuchi, T.; Toramatsu, C.; Fukushi, K.; Irie, T. *J. Med. Chem.* **2009**, *52*, 7284–7288.
- (18) Yoke, J. T.; Weiss, J. F.; Tollin, G. *Inorg. Chem.* **1963**, *2* (6), 1210–1216.
- (19) Weiss, J. F.; Tollin, G.; Yoke, J. T. *Inorg. Chem.* **1964**, *3* (10), 1344–1348.
- (20) Spiteri, C.; Moses, J. E. *Angew. Chem., Int. Ed.* **2010**, *49*, 31–33.
- (21) Buckley, B. R.; Dann, S. E.; Heaney, H. *Chem.—Eur. J.* **2010**, *16*, 6278–6284.
- (22) This mechanistic pathway was proposed by a reviewer, who also suggested several of the experiments described.
- (23) Hein, J. E.; Fokin, V. V. *Chem. Soc. Rev.* **2010**, *39* (4), 1302–1315.
- (24) Brotherton, W. S.; Clark, R. J.; Zhu, L. *J. Org. Chem.* **2012**, *77*, 6443–6455.
- (25) El-Emir, E.; Qureshi, U.; Dearling, J. L. J.; Boxer, G. M.; Clatworthy, I.; Folarin, A. A.; Robson, M. P.; Konerding, M. A.; Nagl, S.; Pedley, R. B. *Cancer Res.* **2007**, *67*, 11896–11905.
- (26) Fidarova, E. F.; El-Emir, E.; Boxer, G. M.; Qureshi, U.; Robson, M. P.; Dearling, J. L. J.; Trott, K. R.; Begent, R. H. J.; Pedley, R. B. *Clin. Cancer Res.* **2008**, *14*, 2639–2646.
- (27) Meyer, T.; Gaya, A. M.; Dancey, G.; Stratford, M. R. L.; Othman, S.; Sharma, S. K.; Wellsted, D.; Taylor, N. J.; Stirling, J. J.; Poupard, L.; Folkes, L. K.; Chan, P.-S.; Pedley, R. B.; Chester, K. A.; Owen, K.; Violet, J. A.; Malaroda, A.; Green, A. J.; Buscombe, J.; Padhani, A. R.; Rustin, G. J.; Begent, R. H. *Clin. Cancer Res.* **2009**, *15*, 4484–4492.
- (28) Cooper, M. S.; Ma, M. T.; Sunassee, K.; Shaw, K. P.; Williams, J. D.; Paul, R. L.; Donnelly, P. S.; Blower, P. J. *Bioconjugate Chem.* **2012**, *23*, 1029–1039.
- (29) Tjuvajev, J. G.; Doubrovin, M.; Akhurst, T.; Cai, S. D.; Balatoni, J.; Alauddin, M. M.; Finn, R.; Bornmann, W.; Thaler, H.; Conti, P. S.; Blasberg, R. G. *J. Nucl. Med.* **2002**, *43* (8), 1072–1083.
- (30) Kim, E. J.; Hong, S. H.; Choi, T. H.; Lee, E. A.; Kim, K. M.; Lee, K. C.; An, G. I.; El-Gamal, M. I.; Cheon, G. J.; Choi, C. W.; Lim, S. M. *Appl. Radiat. Isot.* **2010**, *68* (6), 971–978.
- (31) Darwish, A.; Blacker, M.; Janzen, N.; Rathmann, S. M.; Czorny, S.; Hillier, S. M.; Joyal, J. L.; Babich, J. W.; Valliant, J. F. *ACS Med. Chem. Lett.* **2012**, *3* (4), 313–316.
- (32) Årstad, E.; Yan, R. Processes for producing radiohalogenated bioconjugates and products thereof. WO/2012/022932 (A1), 2012.